

# Adventure

Jerry Cain

CS 106AX

November 10, 2023

*slides constructed by Eric Roberts*

# The Origins of the Internet

- The Internet that has become so much a part of today's world got its start as the ARPANET in the late 1960s.
- The contract to build the ARPANET was awarded to Bolt Beranek and Newman Inc. (BBN), a small, Cambridge-based research and development firm founded by MIT engineers.
- On October 29<sup>th</sup>, 1969, then UCLA student Charley Kline sent the first message on ARPANET. The message was supposed to be the word "login", but only "io" was transmitted before the system crashed.
- A prototype implementation of the ARPANET connecting four nodes came online in early December 1969.
- The initial design for the ARPANET allowed for a maximum of 127 connected computers. Larger networks were possible only after the TCP/IP protocols were adopted in the 1980s.



# Early Designs for the ARPANET

As Larry Roberts envisioned it in his notebooks:

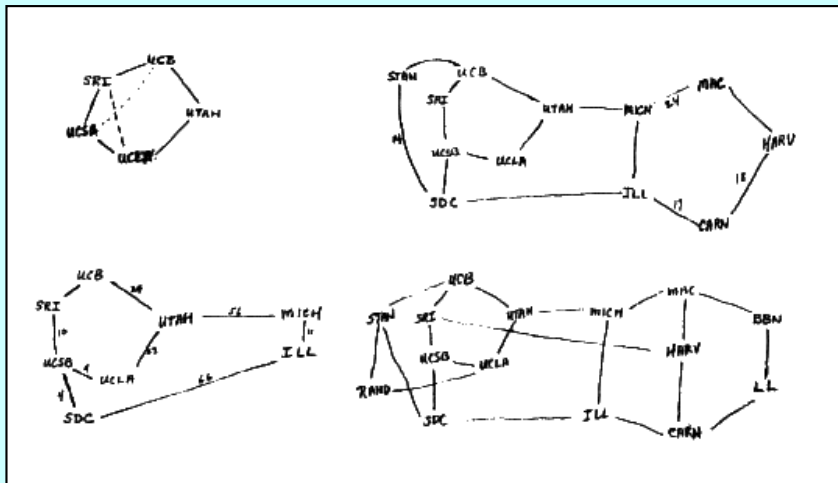

As deployed in 1969:

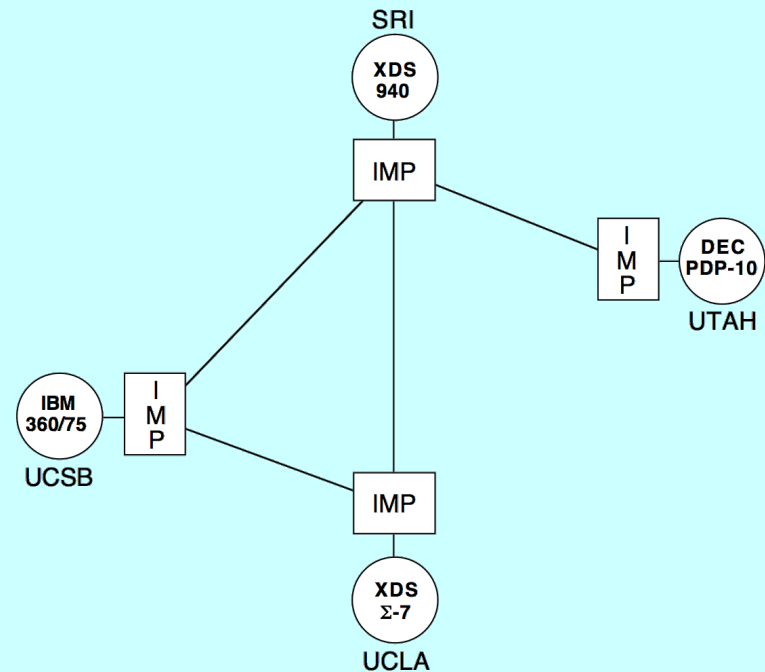

# The ARPANET in 1971

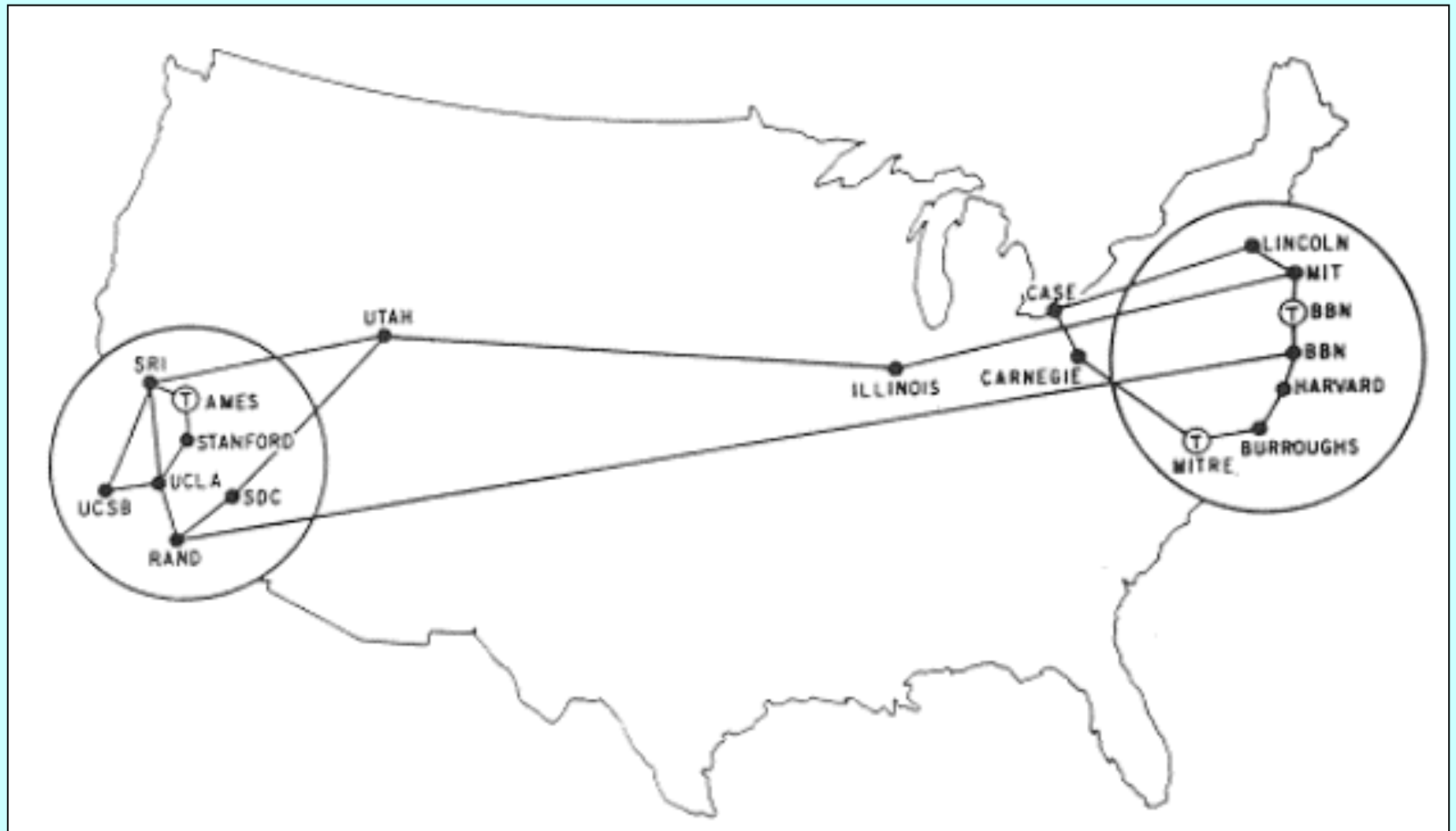

# The ARPANET in 1971

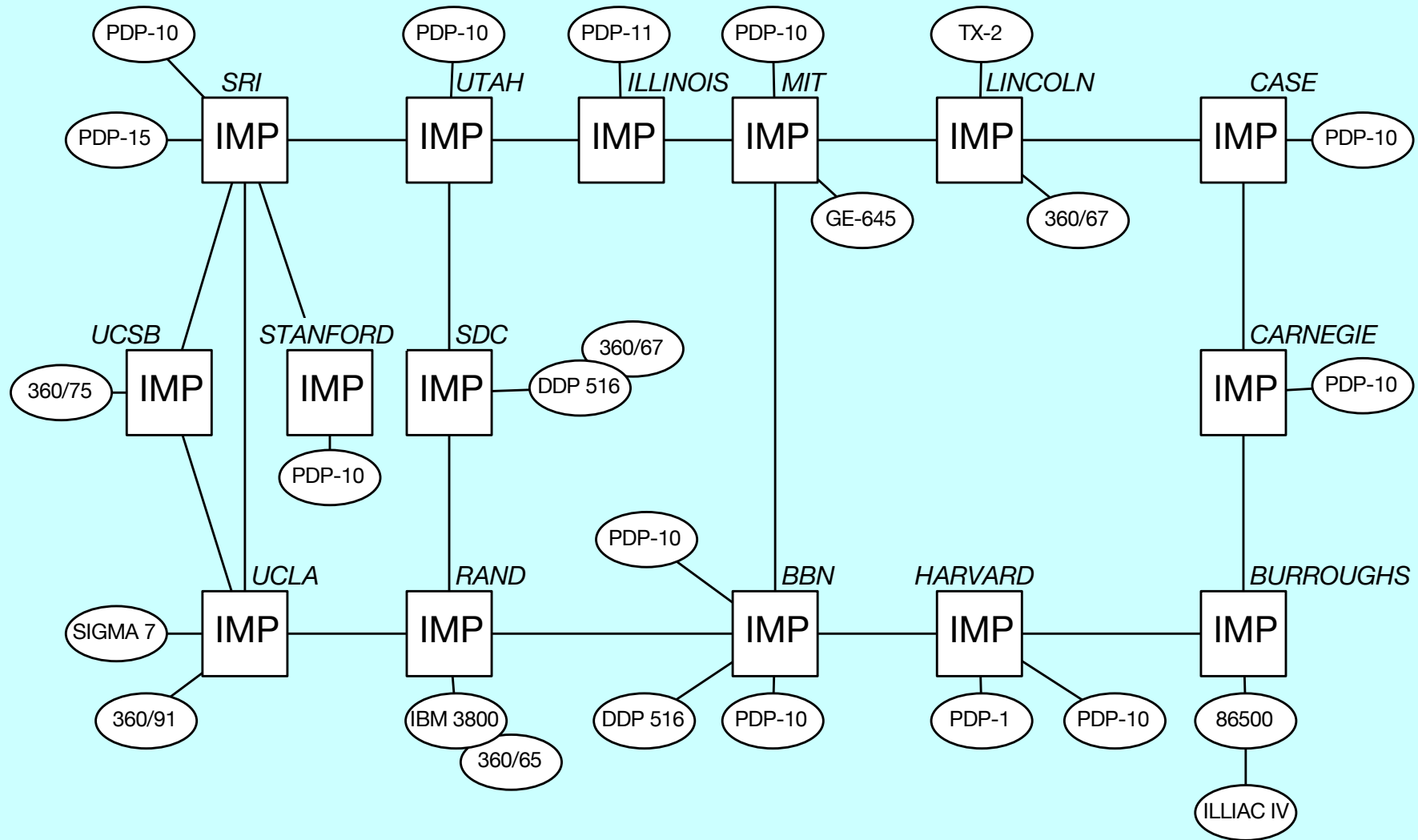

# The ARPANET Directory

NIC 47000

## ARPANET DIRECTORY



DECEMBER 1979

Prepared for:  
DEFENSE COMMUNICATIONS AGENCY  
Washington, D. C. 20305  
On Contract No. DCA 200-C-641

Produced and Published by:  
NETWORK INFORMATION CENTER  
SRI International  
Menlo Park, California 94025

# Life among the Wizards

The history of the Internet has been told in several books. One tells the following story:

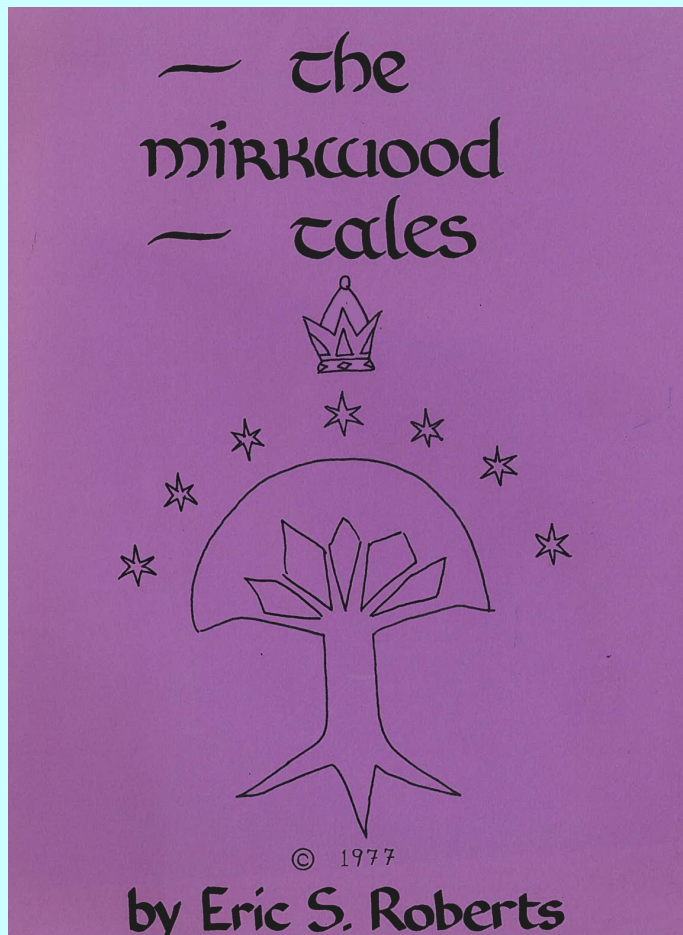

A small circle of friends at BBN had gotten hooked on Dungeons and Dragons, an elaborate fantasy role-playing game in which one player invents a setting and populates it with monsters and puzzles, and the other players then make their way through that setting. The game exists only in the minds of the players.

Dave Walden got his introduction to the game one night when Eric Roberts, a student from a class he was teaching at Harvard, took him to a D&D session. Walden immediately rounded up a group of friends from the ARPANET team for continued sessions. Roberts created the Mirkwood Tales. . . .

One of the regulars was Will Crowther . . .

# The BBN ARPANET Team



Dave  
Walden

Willie  
Crowther



# Willie Crowther's Adventure Game

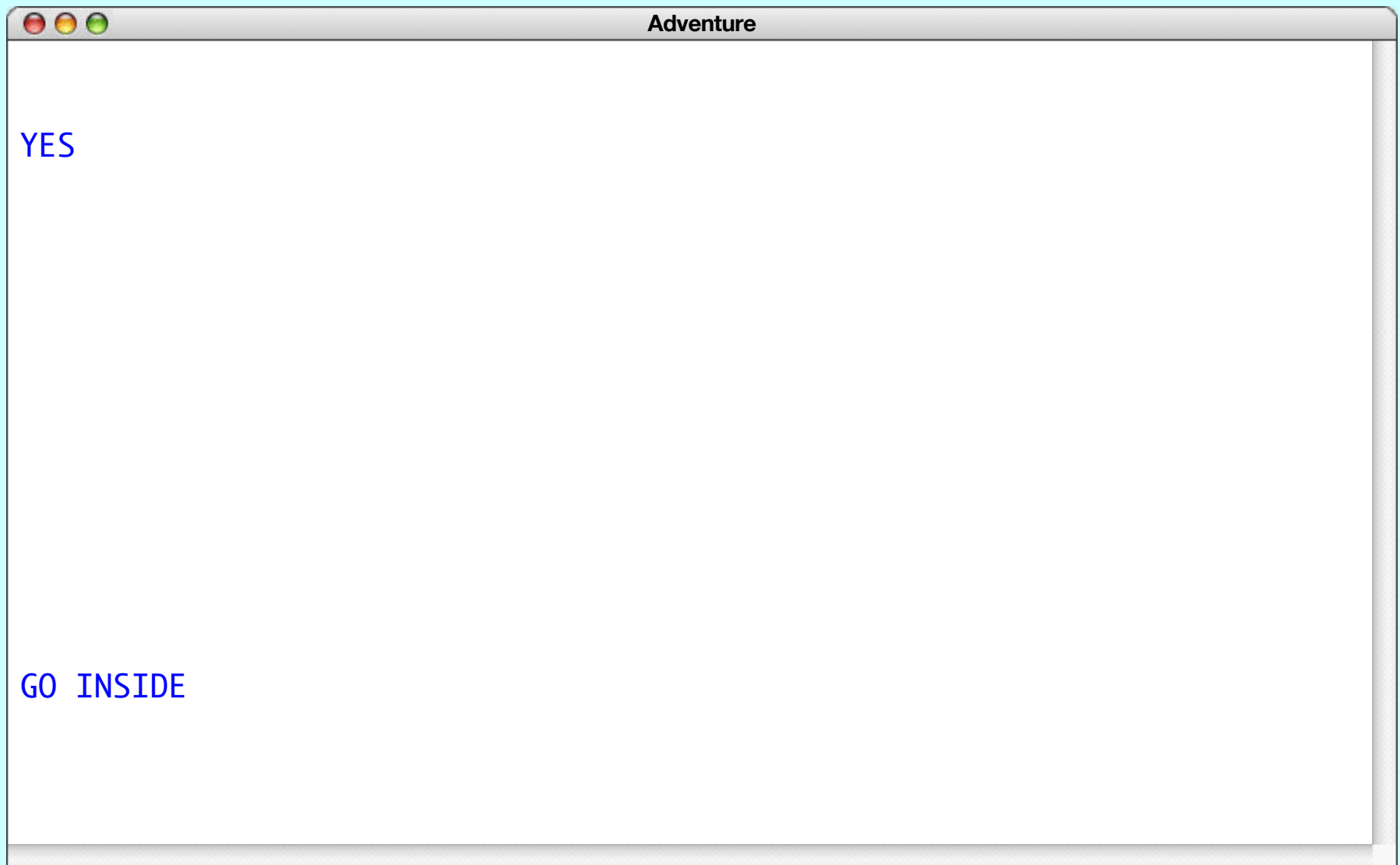

# Willie Crowther's Adventure Game

```
Adventure
Welcome to ADVENTURE!!  Would you like instructions?
YES
Somewhere nearby is Colossal Cave, where others have found fortunes in
RELEASE BIRD treasure and gold, though it is rumored that some who enter are never
seen again.  Magic is said to work in the cave.  I will be your eyes
and hands.  Direct me with natural English commands; I don't under-
stand all of the English language, but I do a pretty good job.
(Should you get stuck, type "HELP" or "?" for some general hints.)
Good Luck!
... some time later ...
- - - -
You are standing at the end of a road before a small brick building.
Around you is a forest.  A small stream flows out of the building and
down a gully to the south.  The road runs up a small hill to the west.
RELEASE BIRD
You are inside a building, a well house for a large spring.
There are some keys on the ground here. . . .
```

# A Brief History of Adventure

- Eric Roberts begins the Mirkwood Tales in early 1975.
- Will Crowther creates Adventure later that year.
- Will moves to Xerox/PARC in 1976.
- Stanford graduate student Don Woods releases an expanded version of Adventure in early 1977.
- Dave Lebling and others from MIT release the first version of Zork in 1977. That game later becomes the foundation of the computer game company Infocom.
- Adventure is ported to a wide variety of platforms by 1980.
- Eric Roberts creates an expanded version in 1984 and uses it as the basis for his first Adventure Contest at Wellesley.

# Classes in the Adventure Game

## **Adventure**

The main program, which gets the program started.

## **AdvGame**

Contains the code and data necessary to play the game.

## **AdvRoom**

Maintains the data structure for each room in the cave.

## **AdvObject**

Maintains the data structure for each object that can be carried by the player.

# Milestone #1

- Adapt the code from the Teaching Machine application so that it uses the class and method names for Adventure.
- Once you finish this milestone, you should be able to wander around the surface geography of the game.

```
Adventure!  
  
You are standing at the end of a road before a small brick  
building. A small stream flows out of the building and  
down a gully to the south. A road runs up a small hill  
to the west.  
> WEST  
You are at the end of a road at the top of a small hill.  
You can see a small building in the valley to the east.  
> EAST  
You are standing at the end of a road before a small brick  
building. A small stream flows out of the building and  
down a gully to the south. A road runs up a small hill  
to the west.  
>
```

# The SmallRooms.txt Data File

OutsideBuilding

Outside building

You are standing at the end of a road before a small brick building. A small stream flows out of the building and down a gully to the south. A road runs up a small hill to the west.

-----

WEST: EndOfRoad

UP: EndOfRoad

NORTH: InsideBuilding

IN: InsideBuilding

SOUTH: Valley

DOWN: Valley

EndOfRoad

End of road

You are at the end of a road at the top of a small hill. You can see a small building in the valley to the east.

-----

EAST: OutsideBuilding

DOWN: OutsideBuilding

# The SmallRooms .txt Data File

InsideBuilding

Inside building

You are inside a building, a well house for a large spring.

-----

SOUTH: OutsideBuilding

OUT: OutsideBuilding

Valley

Valley beside a stream

You are in a valley in the forest beside a stream tumbling along a rocky bed. The stream is flowing to the south.

-----

NORTH: OutsideBuilding

UP: OutsideBuilding

SOUTH: SlitInRock

DOWN: SlitInRock

SlitInRock

Slit in rock

At your feet all the water of the stream splashes into a two-inch slit in the rock. To the south, the streambed is bare rock.

-----

NORTH: Valley

UP: Valley

SOUTH: OutsideGrate

DOWN: OutsideGrate

# Milestone #2

- Implement the `setVisited` and `hasBeenVisited` methods in `AdvRoom`.
- Check this flag in the code that describes a room.
- Once you finish this milestone, the program should use the short descriptions when you enter a previously visited room.

## Adventure!

You are standing at the end of a road before a small brick building. A small stream flows out of the building and down a gully to the south. A road runs up a small hill to the west.

> WEST

You are at the end of a road at the top of a small hill. You can see a small building in the valley to the east.

> EAST

Outside building.

>



# Milestone #3

- Implement the `QUIT`, `HELP`, and `LOOK` commands.
- Once you finish this milestone, the player can end the game, see the help text, and redisplay the room's long description.

## Adventure!

You are standing at the end of a road before a small brick building. A small stream flows out of the building and down a gully to the south. A road runs up a small hill to the west.

> `WEST`

You are at the end of a road at the top of a small hill. You can see a small building in the valley to the east.

> `EAST`

Outside building.

> `LOOK`

You are standing at the end of a road before a small brick building. A small stream flows out of the building and down a gully to the south. A road runs up a small hill to the west.

> `QUIT`

# Milestone #4

- Implement the **AdvObject** class.
- Implement the methods in the **AdvRoom** class that make it possible to keep track of the objects in a room.
- In the **AdvGame** class, write the code to put each object in its initial room (ignore the room name "**PLAYER**" for now).
- Change the code to display a room so that it lists the objects.
- This milestone allows you to see (but not yet take) objects.

```
Adventure!  
Outside building.  
> IN  
You are inside a building, a well house for a large spring.  
The exit door is to the south.  There is another room to  
the north, but the door is barred by a shimmering curtain.  
There is a set of keys here.  
>
```

# The SmallObjects.txt Data File

## KEYS

a set of keys  
InsideBuilding

## LAMP

a brightly shining brass lamp  
BeneathGrate

## ROD

a black rod with a rusty star  
DebrisRoom

## WATER

a bottle of water

## PLAYER

# Milestone #5

- Implement the **TAKE**, **DROP**, and **INVENTORY** commands and any code you need to remember what the player is carrying.

```
Adventure!
You are inside a building, a well house for a large spring.
The exit door is to the south.  There is another room to
the north, but the door is barred by a shimmering curtain.
There is a set of keys here.
> TAKE KEYS
Taken.
> TAKE GOLD
I don't see that here.
> INVENTORY
You are carrying:
  a bottle of water
  a set of keys
> DROP WATER
Dropped.
> DROP KEYS
Dropped.
> INVENTORY
You are empty-handed.
>
```

# Milestone #6

- Implement synonym processing so that the player can use abbreviated forms of the direction verbs and alternative names for the objects.

```
Adventure!
Welcome to Adventure
You are standing at the end of a road before a small brick
building.  A small stream flows out of the building and
down a gully to the south.  A road runs up a small hill
to the west.
> I
You are carrying:
  a bottle of water
> DROP BOTTLE
Dropped.
> W
You are at the end of a road at the top of a small hill.
You can see a small building in the valley to the east.
> D
Outside building.
There is a bottle of water here.
>
```

# The SmallSynonyms.txt Data File

Q=QUIT

L=LOOK

I=INVENTORY

N=NORTH

S=SOUTH

E=EAST

W=WEST

U=UP

D=DOWN

# Milestone #7

- Implement *locked passages*, which are passages that require a particular object be held, as illustrated on the next slide.
- Making this change requires moving the `getNextRoom` code from `AdvRoom` to `AdvGame` so that it can see the objects.

## Adventure!

You are in a 25-foot depression floored with bare dirt.  
Set into the dirt is a strong steel grate mounted in  
concrete. A dry streambed leads into the depression from  
the north.

> INVENTORY

You are carrying:

    a bottle of water

    a set of keys

> DOWN

You are in a small chamber beneath a 3x3 steel grate to  
the surface. A low crawl over cobbles leads inward to  
the west.

There is a brightly shining brass lamp here.

>

# The SmallRooms.txt Data File

OutsideGrate

Outside grate

You are in a 25-foot depression floored with bare dirt. Set into the dirt is a strong steel grate mounted in concrete. A dry streambed leads into the depression from the north.

-----

NORTH: SlitInRock

UP: ~~SlitInRock~~

DOWN: BeneathGrate/KEYS

DOWN: MissingKeys

MissingKeys

Above locked grate

The grate is locked and you don't have any keys.

-----

FORCED: OutsideGrate

BeneathGrate

Beneath grate

You are in a small chamber beneath a 3x3 steel grate to the surface. A low crawl over cobbles leads inward to the west.

-----

UP: OutsideGrate

OUT: OutsideGrate

IN: CobbleCrawl

WEST: CobbleCrawl



# Milestone #8

- Implement *forced motion*, in which the player is forced to move from a room even before reading a command. Forced motion is indicated by the verb **FORCED**.
- It is important to ensure that your implementation of forced motion allows those passages to be locked. This combination of features is used to implement the shimmering curtain.

## Adventure!

You are in a 25-foot depression floored with bare dirt.  
Set into the dirt is a strong steel grate mounted in  
concrete. A dry streambed leads into the depression from  
the north.

> **INVENTORY**

You are carrying:

    a bottle of water

> **DOWN**

The grate is locked and you don't have any keys.

Outside grate.

>

The End